

INNOVATIVE

PRODUCT SHOWCASE

ONE-STOP-SHOP FOR YOUR BODY SHOP NEEDS

2013



Pg. 9 :: SuperStand™



Pg. 5 :: UltraRack™



Pg. 11 :: Paint Prep Cart™ with Masker



Pg. 1 :: Parts Cart B™



INNOVATIVE
TOOLS & TECHNOLOGIES, INC.

U.S. :: 1-866-438-4884 INT'L :: 1-651-415-0733
WWW.INNOVATIVETOOLS.COM

PARTS CARTS & PARTS MANAGEMENT >>>

*Make your Body Shop
a Lean Machine.*



Innovative Parts Cart B™

P/N: SSPC-B
U.S. PATENT 7,314,143, 7,708,156,
OTHER PATENT PENDING



> High-carbon, heat-treated
steel shelf brackets for a
lifetime of trouble-free use

Innovative Parts Carts feature:

- > High-carbon, heat-treated steel shelf brackets
- > Durable powder-coat finish
- > Easily adjusted shelves
- > Shelves detach and hook into dedicated nesting holes for space-saving storage
- > Upper side rails on shelves to prevent parts from sliding off
- > Holds 125 lbs. per shelf
- > Industrial grade, total-lock wheels
- > Customizable with Innovative's Parts Cart Accessories (see p. 3-4)

Innovative Parts Cart B™

P/N: SSPC-B
U.S. PATENT 7,314,143 7,708,156,
OTHER PATENT PENDING

- Includes:
- > 3 Standard shelves
 - > 2 Support arms
 - > 6 Storage hooks
 - > 2 Bungee cords



“ We ordered 15 Parts Carts for our body techs to use for storing teardown parts. They worked so well keeping our parts organized and free from damage that we’ve added an additional 12. Our stalls stay so organized. Couldn’t do without them! ”

INDUSTRY'S ONLY
LIFETIME
WARRANTY

> Shown with optional shelf mat



Innovative Parts Cart A™
P/N: SSPC-A

U.S. PATENT 7,314,143, 7,708,156,
OTHER PATENT PENDING

Includes:

- > 2 Standard shelves
- > 2 Support arms
- > 6 Storage hooks
- > 2 Bungee cords



Innovative Parts Cart C™
P/N: SSPC-C

U.S. PATENT 7,314,143, 7,708,156,
OTHER PATENT PENDING

Includes:

- > 6 Standard shelves
- > 4 Support arms
- > 6 Storage hooks
- > 2 Bungee cords



Innovative Wall SuperStorage™

P/N: SSPC-W

U.S. PATENT 7,314,143

The benefits of the Parts Cart, without the wheels

- > Shelves easily adjust in seconds
- > Holds 125 lbs. per shelf
- > With a zero footprint, puts small spaces to work
- > Creates extra storage or work areas
- > High-carbon, heat-treated, easy-adjust shelves
- > 16 sq. ft. of shelving
- > Durable powder-coat finish, good for a lifetime
- > Mounting hardware included
- > Includes: 3 Standard Shelves

PARTS CARTS ACCESSORIES >>

BE PARTS SMART :: CUSTOMIZE YOUR CART



Headlight Bag
24" x 38"



Trim Panel Bag
49" x 38"

Innovative Padded Parts Bags™

Padded protection for expensive parts

- > Constructed of heavy-duty nylon exterior, soft padded nylon interior
- > Protects delicate and expensive parts from dust and damage
- > Industrial grommets allow bags to hang from Parts Carts
- > Bags can also be stored in the vehicle, preventing interior damage
- > Heavy-duty, two-way zipper for convenient handling
- > Two sizes available:
SSPC-HB – 24" x 38" – Headlight Bag
SSPC-TB – 49" x 38" – Trim Panel Bag



Innovative Hanger Bracket™
P/N: SSPC-HBK

- > Convenient, three-hook bracket for hanging padded parts bags and light parts
- > Quickly installs onto any Innovative Parts Cart
- > Durable powder-coat finish



> Total-lock wheels provide a unique braking system triggered by the touch of a toe



Innovative Parts Cart B™

Cart shown above with the following available options:

- > SSPC-B Parts Cart B
- > SSPC-PT Panel Train
- > SSPC-DB Deep Basket
- > SSPC-HT Hardware Tray
- > SSPC-PP Parts Pan
- > SSPC-HBK Hanger Bracket
- > SSPC-HB Headlight Bag
- > SSPC-RO RO Holder

*Innovative Parts Carts are often copied, never duplicated.
The only ones in the industry backed by a lifetime warranty.*

Innovative RO Holder™
P/N: SSPC-RO

- > Acrylic dry-erase board clearly identifies each job
- > Clear, two-pocket envelope organizes paperwork and keeps it with the job
- > Quickly mounts to the top of any Innovative Parts Cart
- > Rotates 360 degrees for maximum visibility



Innovative Panel Train™
P/N: SSPC-PT

- > Holds and protects up to three large panels
- > Extensive padding means no metal-on-metal contact, no damage
- > Industry's only convenient post-storage holder
- > Nine post settings for custom adjustment
- > Can be easily added to Innovative Parts Carts A or B
- > Folds up and stays up for compact, stable storage
- > Durable powder-coat finish resists damage



Innovative Parts Pan™
P/N: SSPC-PP

- > Conveniently stores underneath any Innovative Parts Cart shelf
- > Easily removed with a quick "slide and pull"
- > Organizes smaller parts and minimizes loss



Innovative Hardware Tray™
P/N: SSPC-HT

- > Conveniently stores underneath any Innovative Parts Cart shelf
- > Easily removed with a quick "lift and pull"
- > Organizes small nuts, bolts, screws, and clips, etc.
- > Speeds up reassembly time
- > Comes with a grease pencil to mark the clear lid

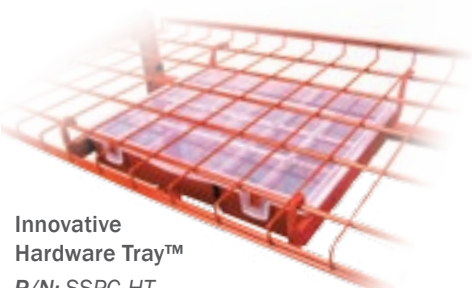

Innovative Deep Basket™
P/N: SSPC-DB

- > Safeguards small parts with unique, flip-down front for easy part loading/unloading
- > Completely folds down allowing carts to nest
- > Durable powder-coat finish resists damage
- * **Replaces one standard shelf Support Arms not included**



Innovative Shelf Mat™
P/N: SSPC-SM

- > Durable, easy-to-clean, chemical-resistant work surface
- > Quickly installs onto any Innovative Parts Cart shelf
- > Water-jet cut for exact fit every time



Innovative Protective Mat™
P/N: SSPC-PM

- Surface protection perfection
- > Form-fitted rubber mat covers entire shelf; provides protection for painted or delicate surfaces
 - > Completely eliminates metal-on-metal contact



PAINT & REPAIR STANDS



Position Parts for a Perfect Finish, Everytime.

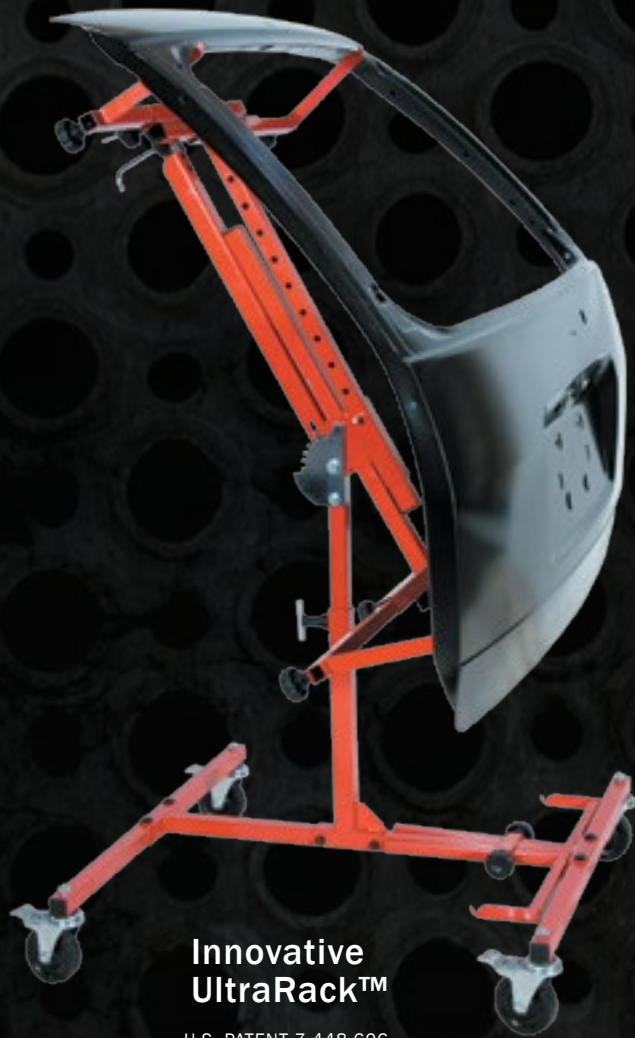

Innovative UltraRack™

U.S. PATENT 7,448,606

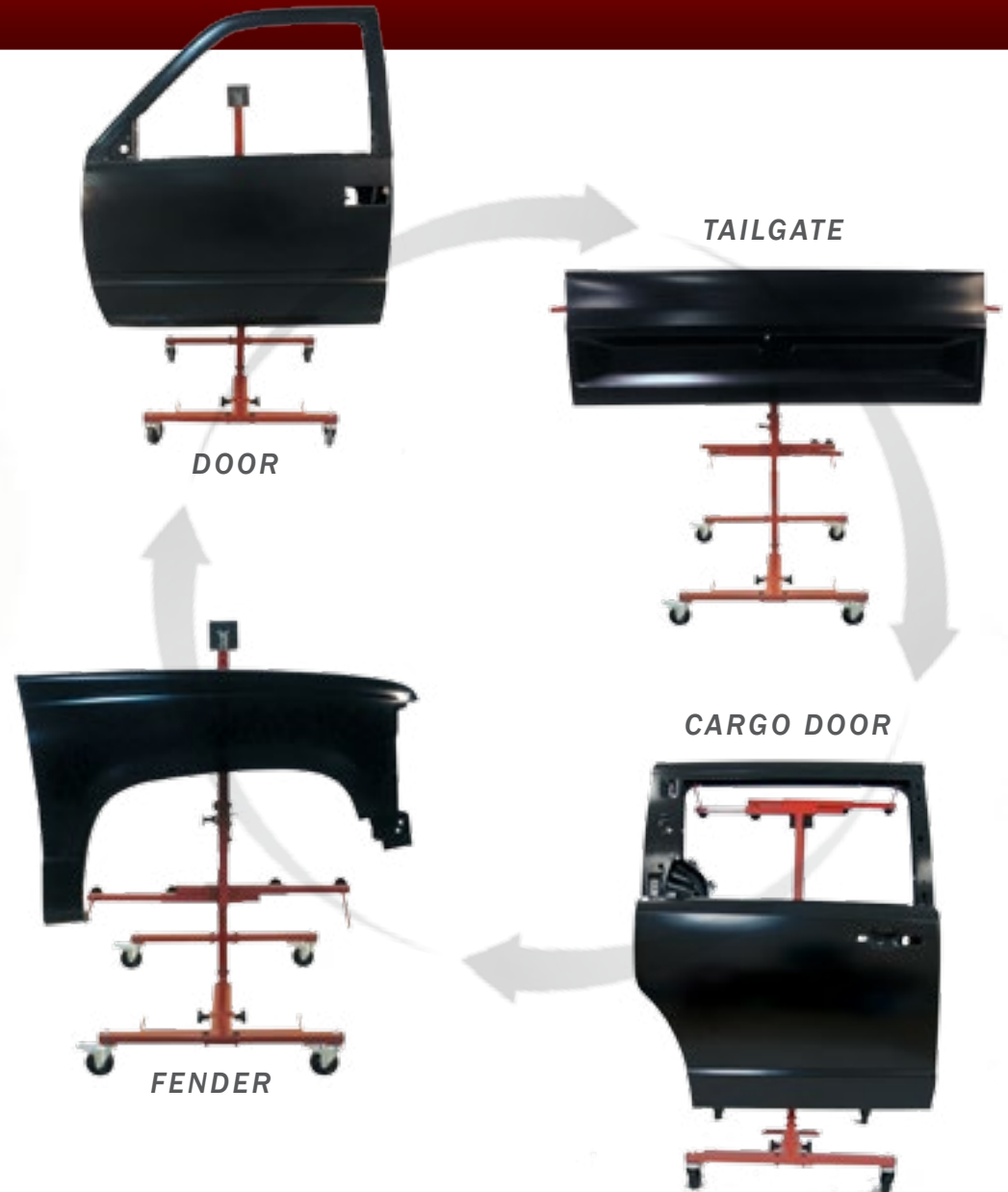

“We had two other brands of painting racks in our shop. Once we bought a couple of UltraRacks, it was hard to get anyone to use the others anymore. This rack is five stars in my book.”



Innovative UltraRack™

P/N: URPS

- > Holds hoods, tailgates, doors, lift gates, deck lids, cargo doors and fenders
- > Efficient single-hand operation, non-interrupted spraying for smooth-as-silk finishes
- > Seven locking positions mimic the part's position on the vehicle for a seamless match
- > Complete system – no accessories needed
- > Rotates panel 90 degrees to ensure proper paint coverage every time
- > Protective rubber boots keep critical areas free of overspray
- > Four industrial-grade, total-lock caster wheels for stability; zero movement when locked
- > Durable powder-coat finish



> Efficient single-hand operation allows you to spray both sides without setting your spray gun down

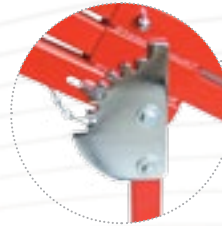

> Seven locking positions mimic the part's position on the vehicle for a better color and texture match



> Total-lock wheels provide a unique braking system triggered by the touch of a toe



32" (width)
32" (depth)



PAINT & REPAIR STANDS >>

RELIABLE :: DURABLE :: EFFICIENT :: GUARANTEED

Innovative X-Stand™

U.S. PATENT 7,988,137



> Padded support arms
adjust and lock to
panel's contours



Innovative X-Stand™

P/N: I-XS

U.S. PATENT 7,988,137

- > Total flexibility; fits any repair, paint or storage job – including glass
- > Total vertical and horizontal adjustability
- > Creates a comfortable work level for techs from tall to small
- > Accommodates panels of any width and size, perfect for door repair
- > Four industrial grade, total-lock caster wheels for mobility; zero movement when locked
- > Durable powder-coat finish makes it look as good as it works – for a long time
- > Pad height adjustment from 37" – 44"
- > Pad width adjustment from 14" – 30"

“ The X-Stand has added a mobile work area for our shop. The guys use it for just about any big part. I’m planning on adding another soon. This one’s always in use! ”



PAINT & REPAIR STANDS >>

RELIABLE :: DURABLE :: EFFICIENT :: GUARANTEED

Innovative SuperStand™



> Pinch or Pin. The SuperStand swivel clamp arms can easily adjust and securely hold almost any cover.



> Total-lock wheels provide a unique braking system triggered by the touch of a toe



> Nestable storage



P/N: SS-II



Innovative SuperStand™

P/N: SS-II

U.S. PATENT 6,173,947

- > Holds any plastic bumper cover securely without touching the painted surface
- > Makes prep, repairs and painting faster and easier
- > Cover can be rotated 90 degrees to ensure proper paint coverage time after time
- > Five locking positions for a perfect angle every time
- > Protective rubber boots keep critical areas overspray-free
- > Four industrial-grade, total-lock caster wheels for stability; zero movement when locked
- > Durable powder-coat finish withstands heat and rough handling

Optional Innovative Spoiler-Mirror Kit

P/N: SMK

- > Holds any spoiler or mirror securely without touching the painted surface
- > Paint spoilers at any angle to ensure proper paint coverage every time
- > Changes out in seconds
- > Durable finish

Spoiler-Mirror Kit

P/N: SMK



Replacement Support Arm Kit

P/N: SAS

Includes:

- > 1 Right support arm
- > 1 Left support arm
- > 2 Plastic hand knobs
- > 2 Rubber sleeves
- > 2 Ball socket boots



Replacement Support Arm Kit
P/N: SAS

POINT OF USE MATERIAL CARTS >>>

Make Your Supply Room
Mobile & Organized.



**Innovative
Paint Prep Cart
with Masker™**
P/N: I-MCWM

| | Innovative Paint Prep Cart™ with Masker P/N: I-MCWM | Innovative Paint Prep Cart™ P/N: I-MCPC | Innovative Detailer Cart™ P/N: I-MCDC | Innovative Bodyman Cart™ P/N: I-MCBM |
|---------------------------------|---|--|--|---|
| BARCODE TAG HOLDERS | 40 | 40 | 40 | 50 |
| SINGLE HOOK P/N: I-SH | 4 | 4 | 4 | 4 |
| DOUBLE HOOK P/N: I-DH | 2 | 2 | 2 | 2 |
| ROLL PAPER HOLDER P/N: I-RSH | 1 | 1 | - | 1 |
| 4X17" BASKET P/N: I-4x17 | 1 | 1 | 1 | 3 |
| 5X17" BASKET P/N: I-5X17 | 1 | 1 | - | 2 |
| 7X17" BASKET P/N: I-7X17 | 3 | 3 | 2 | 2 |
| 8X17" BASKET P/N: I-8X17 | - | - | 1 | 1 |
| AEROSOL BASKET P/N: I-CH | 1 | 1 | 3 | 1 |
| GLOVE BOX HOLDER P/N: I-GB | 1 | 1 | 1 | 1 |
| MASKER OPTION P/N: I-MO | 1 | - | - | - |
| LARGE BOX MOUNT P/N: I-BM | 2 | - | - | - |
| BOTTLE RACK P/N: I-BR | - | - | - | 1 |
| 5" DISK HOLDER P/N: I-DH5 | - | - | - | 1 |
| BUFFER PAD HOLDER P/N: I-PH | - | - | 1 | - |
| TRASH CAN P/N: I-TC | 1 | 1 | 1 | 1 |
| SPRAY GUN HOLDER P/N: I-GH | 1 | 1 | - | 1 |

Base Material Cart Measurements > Height 67" | Width 35" | Depth 22"

Organize and Track Materials Like Never Before with Innovative's Paint Prep, Detailer & Bodyman Carts.



**Innovative
Paint Prep Cart™**
P/N: I-MCPC



**Innovative
Detailer Cart™**
P/N: I-MCDC



**Innovative
Bodyman Cart™**
P/N: I-MCBM

Every Innovative Material Cart:

- > Rolls into the work area for greater efficiency
- > Keeps supplies handy and techs on the job
- > Stores material and supplies in full view from any angle
- > Facilitates easy-to-use bar code inventory system
- > Enables repair and process controls for consistent quality, time after time

MATERIAL CARTS ACCESSORIES >>

EFFICIENT MATERIALS MANAGEMENT :: INCREASED PRODUCTIVITY

Material Cart Baskets:

4"X17" Basket

P/N: I-4X17

5"X17" Basket

P/N: I-5X17

7"X17" Basket

P/N: I-7X17

8"X17" Basket

P/N: I-8X17

Aerosol Basket

P/N: I-CH



5" Disc Holder

P/N: I-DH5

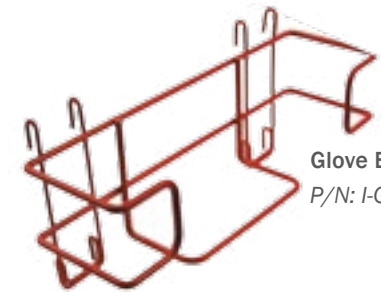

Glove Box Holder

P/N: I-GB



Roll Paper Holder

P/N: I-RSH

Buffer Pad Holder

P/N: I-PH



Large Box Mount

P/N: I-BM



Shelf Mat

P/N: I-SM

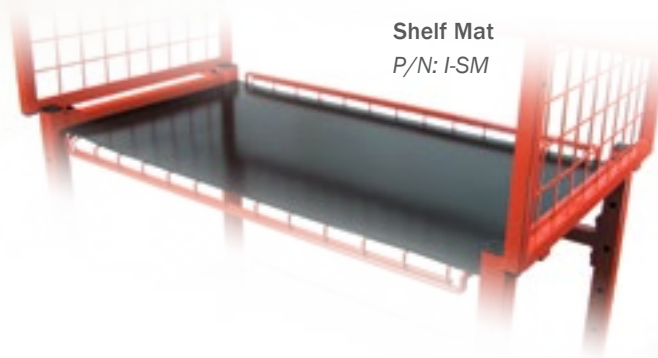

Box Holder

P/N: I-BH

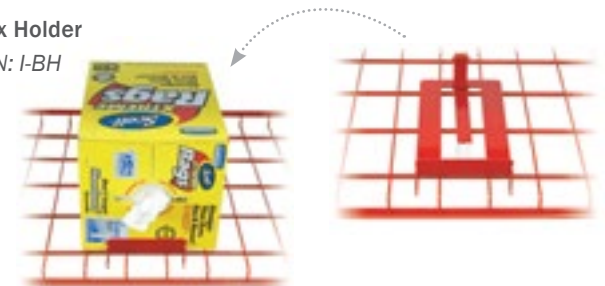



Innovative Masker Option
 P/N: I-MO
 > Holds 6" - 18" paper rolls



Single Hook
 P/N: I-SH



Double Hook
 P/N: I-DH



Bottle Rack
 P/N: I-BR



Spray Gun Holder
 P/N: I-GH

Innovative Vertical Masker Option



> Lower cup design prevents plastic from dropping

Innovative Vertical Masker Option

P/N: I-MO36

- > Industry's only 36" stainless-steel paper tear blade
- > Plastic sheeting dispenses from box to keep it dust-free
- > Nylon bushings for easy material rotation
- > Heavy-duty all-steel construction
- > Durable powder-coat finish

BUMPER, PANEL & PARTS STORAGE



*Innovative Products.
Designed & Made by a Tech for Techs.*



**Innovative
Panel-Cart™**

Folded for half-usage mode



70"
Full-usage mode



15"
Folds to store in 2 sq ft of space

Innovative Panel-Cart™
P/N: I-PC

- > Industry's only panel cart that folds up –and stays up– when not in use
- > Holds up to six large panels and glass
- > Extensive padding – no metal-on-metal contact; no damage
- > Can be used as a whole or only a half-unit
- > Convenient post-storage holder
- > Twenty-six easy settings for custom adjustment
- > Heavy-duty lockable wheels provide easy mobility
- > Folds to store in only two square feet of space

INDUSTRY'S ONLY
**LIFETIME
WARRANTY**

Innovative Wall Bumper Storage™

P/N: MBW

- > Totally adjustable wall racking system puts big bumper covers in their place and saves space
- > Support arms adjust in seconds to customized your storage needs
- > Holds up to six large bumper covers
- > Support arms fold down when not in use
- > High-carbon, heat-treated steel construction holds heavy loads
- > Can be mounted as one unit or two
- > Durable powder-coat finish stands up to rough handling



U.S. PATENT 7,314,143

Includes:

- > Four Mounting rails
- > Twelve 18" Support arms
- > Mounting hardware



- > Heavy gauge steel for full loads, folds down when not in use.



U.S. PATENT 7,314,143

Includes:

- > Four 23" Support arms
- > Twelve 18" Support arms

Innovative Mobile Bumper Storage™

P/N: MBM

- > Support arms adjust in seconds to customize your storage needs
- > Holds up to eight large bumper covers
- > Four extra-long arms for oversized bumpers
- > High-carbon, heat-treated steel construction stands up to big loads
- > Four locking wheels for easy mobility; zero movement when locked
- > Durable powder-coat finish stands up to rough handling

INNOVATIVE PRODUCTS >>

LIMBER AND MUSCULAR TO LIFT AND HOLD BIG LOADS- EASY STORAGE



Innovative Door-Jack™
P/N: I-DJ

INDUSTRY'S BEST
3YR
WARRANTY

- > Now one tech can handle big bumpers and doors alone
- > Industry's only 8" front-to-back tilting adjustment
- > Ample padding, no metal-on-metal contact, no damage
- > Adjusts from 7" to 32" from the floor
- > Custom 4" total-lock, easy-glide wheels; no swivel or creep when wheels are locked
- > Side-to-side tilt adjustment for easy panel mounting
- > Wide stance for added stability
- > Heavy gauge steel with durable powder-coat finish



> Pad width adjust
from 8" - 20" wide



8" tilt

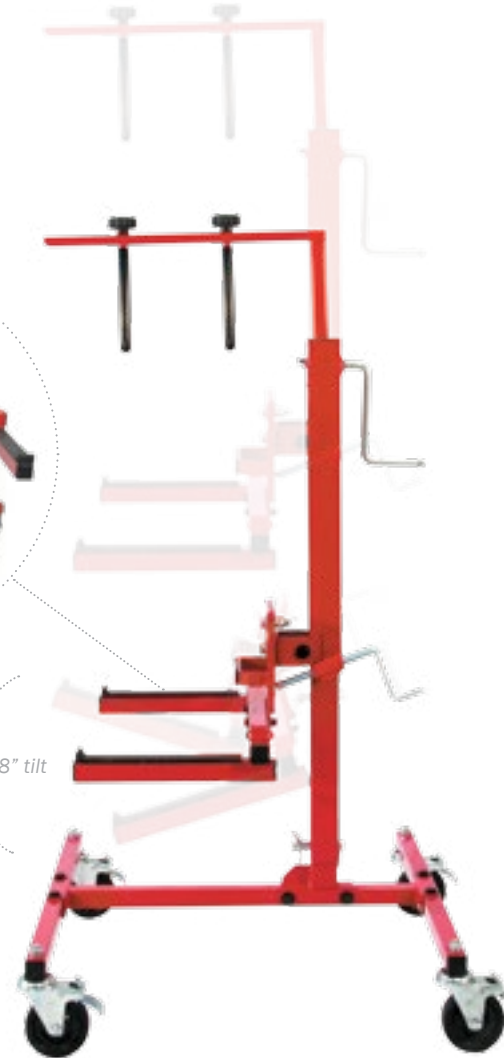



> Freestanding storage design

INDUSTRY'S ONLY
LIFETIME WARRANTY

Innovative Truck Bed Dolly™

P/N: I-TBD

- > Easy 4-way adjustment to fit any size truck bed
- > Also holds panels and hoods
- > Multiple adjustments for ideal work height
- > Makes repairs, prep and painting more efficient
- > Custom 8" total-lock, easy-glide wheels ensure zero movement when locked - no swivel, no creep
- > Rated to hold up to 600 lbs.
- > Powder-coat finish withstands heat and rough handling
- > Folds to a small footprint for space-saving storage
- > Only dolly with a lifetime guarantee



> 8" solid-core total-lock wheels for complete mobility, stability and locking



Innovative Bed-Lift™

P/N: I-BL

- > Allows one-person truck bed removal
- > Lift pickup truck beds easily and safely
- > Four rubber-padded support arms prevent damage
- > Adjustable center hook allows even weight distribution
- > Adjusts from 40" to 70" wide
- > Rated at 600 lbs. capacity
- > Durable powder-coat finish
- > Lifetime warranty
- > For use with engine hoist or cherry picker



MOBILE MASKER & DISPENSER >>



P/N I-MMD

Innovative Mobile Masker

P/N: I-MM

- > Four industrial grade, total-lock caster wheels for zero-turn mobility; zero movement when locked
- > Holds one roll of 12" paper and two rolls of 18" paper
- > Easy loading of paper rolls and tape
- > Convenient basket for extra tape, tools and supplies
- > Thick steel blades allow for longevity while maintaining smooth cutting
- > Narrow 19" profile makes it easy to maneuver around the shop
- > Heavy-duty all steel construction
- > Durable powder-coat finish
- > Guaranteed to out-last and out-perform any other masker on the market
- > Lifetime warranty
- > Measures: 19" W x 33" L x 45" H

Innovative Mobile Masker Deluxe

P/N: I-MMD

All the features of the Mobile Masker plus the following :

- > Holds a roll of 36" paper and a box of plastic sheeting
- > Industries only 36" stainless steel tear blade for clean, smooth cuts
- > Plastic dispenses from box to keep it dust free
- > Nylon bushings for easy material rotation
- > Heavy-duty steel construction
- > Durable powder-coat finish
- > Measures: 19" W x 33" L x 54" H

Optional Trash Can

P/N I-TC



P/N I-MM

Innovative Plastic Holder

P/N: I-PBH

- > Unique design can mounted vertically or horizontally
- > Four industrial-grade magnets for secure holding power
- > Can easily be moved to any metal surface in or out of your paint booth
- > Plastic sheeting dispenses from box to keep it dust-free.
- > Upper & lower roll-cups prevents plastic from dropping.
- > Nylon bushings for easy material rotation
- > Heavy-duty steel construction
- > Durable powder-coat finish

> Upper & lower roll-cups prevents plastic from dropping.



INNOVATIVE CORNER STORE >>



Innovative Corner Store™ P/N I-CS

- > Designed by a tech for a tech
- > Get your work surface back while cleaning up clutter
- > Made with steel tubing along with heavy-gauge wire, all with a durable powder-coat finish
- > Baskets and hooks easily move to meet your storage needs
- > Durable steel tubing with heavy gauge wire
- > Customize your Corner Store with available options
- > Dimensions 26" H x 20" D x 26" W

Includes:

- > 2 Double hooks - P/N I-DH
- > 2 Single hooks - P/N I-SH
- > 1 4x17 basket - P/N I-4x17
- > 2 5x17 baskets - P/N I-5x17
- > 1 7x17 basket - P/N I-7x17
- > 1 Aerosol basket - P/N I-CH
- > 1 Glove box holder - P/N I-GB

> Mounts quickly and securely with metal guides and 3 large magnets

PERFORMANCE,
PRODUCTIVITY &
UNBEATABLE QUALITY.
GUARANTEED.



INNOVATIVE
TOOLS & TECHNOLOGIES, INC.

Innovative Tools & Technologies, Inc. ::: 2016 Gateway Circle ::: St. Paul, MN 55038 USA
U.S.: 1-866-438-4884 ::: International: 1-651-415-0733 ::: www.innovativetools.com

